

## **Digital Simulation Experiences of Pre-service Science Teachers: An Example of Circuits**

**Gülşah Uluay**<sup>i</sup>  
Ordu University

### **Abstract**

The purpose of this study is to investigate the self-efficacy levels of pre-service science teachers who participated in a workshop about physical laboratory implementations supported by digital simulations and also to determine their views on digital simulations. For this purpose, a 6-week workshop was designed based on a digital simulation program called Crocodile Physics. The participants in the research were 16 university students who were studying in the science education department of a public university. This study includes quantitative and qualitative data. The Science Learning Self-Efficacy (SLSE) scale was used to collect quantitative data. Qualitative data was collected with a structured interview form. According to analysis results for quantitative data, self-efficacy levels towards physics of pre-service teachers were significantly developed. Analysis results of qualitative data showed that pre-service science teachers mostly have a positive tendency to integrate digital simulations into educational environments.

**Keywords:** Digital Simulation, Physics, Self-Efficacy, Laboratory, Pre-Service Teacher.

**DOI:** 10.29329/ijpe.2021.346.2

---

<sup>i</sup> **Gülşah Uluay**, Assist. Prof. Dr., Education Faculty, Ordu University, ORCID: 0000-0002-6365-5122

**Email:** gulsahuluay@gmail.com

## INTRODUCTION

The field of instructional technologies bears witness to developments in interactive multimedia learning environments such as computer-assisted instruction over many years (Jonassen, 1992; Yoder, 1994) and research in this field emphasizes contributions to learning processes offered by technology. According to Roschelle, Abrahamson and Penuel (2004), technology supports student learning in four basic dimensions of active participation, cooperative learning, real world cases, and ordinary and immediate feedback. Traditional methods transform into constructivist methods with technology use in the learning process (Matzen & Edmunds, 2007) since technology provides limitless opportunities to develop instructional experiences, increase academic chances, and improve skills in critical studies (Wilson, 2002). In this context, technology-rich classrooms train critical thinkers and leaders (Bingimlas, 2009) and also technology can promote learners in developing higher order thinking skills and metacognitive skills (Wang et al., 2004).

Although technology is described as a catalyst required for constructivism (Collins, 1990), several barriers were determined in integrating technology into education (Bingimlas, 2009). Fullan and Stiegelbauer (1991) determined these barriers as beliefs, attitudes, and pedagogical ideologies; content knowledge; pedagogical knowledge; and changed instructional resources, technology, and materials. According to Ertmer and Ottenbreit-Leftwich (2010), four factors termed knowledge and skills, self-efficacy, pedagogical beliefs, and culture are key variables for technology integration. All around the world, teacher training institutions attempted to overcome these barriers and began to integrate technology into their curriculums to make pre-service teachers understand pedagogic reasons for technology use by experiencing how technology can support learning and teaching in different subjects (Tondeur et al., 2012). This is important since it is expected that institutions train pre-service teachers who can sufficiently use technology for their own educational implementations (Brun & Hinostroza, 2014). One of the approaches that can be used to meet this expectation is digital simulations.

Digital simulations are defined as computational models of real or hypothesized situations or phenomena that enable users to discover the effects resulting from manipulating or changing parameters within the models (Clark, Nelson, Sengupta & D'Angelo, 2009). In another definition according to Miller (1984), digital simulations can be explained as being representations of reality. Indeed, digital simulations offer their users an opportunity to discover scientific phenomena which they experience in daily life (Clark, Nelson, Sengupta & D'Angelo, 2009). Digital simulation programs can be described as a virtual laboratory with all virtual components (Le Thang, 2014).

Several advantages of digital simulations in educational environments were emphasized in the related literature as follows: Digital simulations:

- support self-efficacy (Bautista & Boone, 2015; Gegenfurtner, Quesada-Pallarès & Knogler, 2014; Kozlowski, Gully, Brown, Salas, Smith & Nason, 2001);
- support learning (Squire, Barnett, Grant & Higginbotham, 2004);
- support active learning (Miller, 1984; Woodward, Carnine & Gersten, 1988);
- support motivation (Clark, Nelson, Sengupta & D'Angelo, 2009; Dekkers & Donatti, 1981);
- direct exploring (De Jong, 1991);
- ensure multiple representations (Lindgren & Schwartz, 2009);
- build accurate intuitive understandings of concepts (Clark, Nelson, Sengupta & D'Angelo, 2009);

- are more practical instead of performing an activity which has several characteristics such as being expensive, time-consuming and dangerous (De Jong, 1991), and is inaccessible in daily life (Clark, Nelson, Sengupta & D'Angelo, 2009);

- provide

an interactive learning environment (Lindgren & Schwartz, 2009).

### **Self-Efficacy**

Self-efficacy is defined as a personal judgment about the individual's own ability with regard to actualizing certain behaviors and actions to achieve specific goals and expected results (Bandura, 1997). Self-efficacy is also described as self-confidence of the individual that they can perform the duties assigned to them (Kinzie et al., 1994). Based on these definitions, the individual's thoughts about themselves about issues such as achieving a task which they have undertaken or reaching a determined goal are explained with self-efficacy. Indeed, Bandura (1995) emphasized that self-efficacy is separate from whether a task can be achieved or not, and underlines that self-efficacy is the belief that the task can be achieved. The self-efficacy judgment indicates how much effort individuals will make and how long they will persist when faced with obstacles or deterrent experiences (Bandura, 1982).

Bandura (1997) explains the sources of self-efficacy with 4 factors of mastery experiences, vicarious experiences, social persuasion experiences and emotional arousal. Mastery experiences are experiences gained through a successfully completed task which have a positive impact on an individual's confidence in their ability to achieve a similar task. On the contrary, failure of the task, which is the opposite of this situation, will have a negative effect on the individual's confidence for future tasks. Vicarious experiences are formed through the individual's observations about the performance of others who are performing a task. The successes and failures of others performing a task influence the individual's self-efficacy beliefs. This effect is especially constituted when the individual has no experience with the task. Social persuasion experiences stem from others' verbal suggestions about the abilities of the individual. These suggestions can encourage and discourage individual beliefs about abilities. Emotional arousal can be explained by physiological states such as cheerfulness, sadness, anxiety or stress. These states affect individuals' self-efficacy beliefs. For example, an individual's mood being one of the positive feelings or attitudes such as cheerfulness influences the self-efficacy belief of the individual positively (Bandura, 1997).

The reason for examining self-efficacy towards physics in this study is the common belief that physics is seen as a challenging subject (Lindstrøm & Sharma, 2011). Similarly, it can be stated that students have low self-efficacy beliefs towards physics. For example, Sawtelle et al. (2010) reported that traditional lecture classrooms negatively influence physics self-efficacy levels of students. In the same study, modeling instruction can positively affect self-efficacy. In addition to this, Fencil and Scheel (2004) determined that a traditional lecture environment negatively impacts physics self-efficacy beliefs of students. In this context, new methods such as digital simulations may be integrated into physics lectures. In addition, the value of physics is also mentioned from the perspective of STEM education, which was emphasized in educational research especially in recent years (Li, Wang, Xiao & Froyd, 2020). As a matter of fact, basic physics subjects are required for all STEM fields except mathematics (Sawtelle, Brewe & Kramer, 2012). In addition, when studies investigating the relationship between self-efficacy and gender in the field of physics are examined, there are research results emphasizing that females have lower levels of self-efficacy than males (Lindstrøm & Sharma, 2011; Nissen & Shemwell, 2016; Yerdelen-Damar & Peşman, 2013). One of the factors that cause fewer females to enter STEM fields is self-efficacy (Marshman, Kalender, Nokes-Malach, Schunn & Singh, 2018). Considering the global importance given to STEM education, together with the instrumental role that STEM fields have assumed for economic growth and productivity (Takeuchi, Sengupta, Shanahan, Adams & Hachem, 2020), the importance of self-efficacy towards physics is

remarkable. In this context, it is recommended to create active learning environments to ensure self-efficacy development (Dou, Brewes, Zwolak, Potvin, Williams & Kramer, 2016).

In the relevant literature, there are studies emphasizing the positive effects of digital simulations on self-efficacy development. For example, a study which examined the effect of digital simulation-based learning on self-efficacy by Kozlowski, Gully, Brown, Salas, Smith and Nason (2001) was conducted with 60 participants, and the research results stated that the self-efficacy levels of the participants improved with a computer simulation over 2 days. Similarly, in another study conducted by Bautista and Boone (2015) with 62 pre-service early childhood teachers, a teaching simulation called TeachME™ Lab was used. The researchers reported that the self-efficacy levels of the participants in science teaching increased at the end of the application process. In addition to this, when the relevant literature is examined, there is a deficiency in the field of educational research examining the possible effects of simulations on self-efficacy (Gundel, Piro, Straub & Smith, 2019). In this context, this study can contribute to the literature.

## METHOD

### Research Model

In this study, a mixed method research design was used. Mixed method research designs are procedures to collect and analyze data by using a combination of both qualitative and quantitative methods in a single study or in a multiphase series of studies (Creswell & Plano Clark, 2011). In contrast with any single method, using both qualitative and quantitative methods offer the opportunity to develop a better understanding with respect to research problems and questions (Creswell, 2012). According to Creswell (2012), six types of mixed method research are generally used for educational surveys and embedded design was used in this study. The purpose of this research design is to collect qualitative and quantitative data simultaneously or sequentially, with one form of data used for promoting the other form of data (Creswell, 2012). In the present study, qualitative data was used to support quantitative data and develop detailed understanding of the results.

### Purpose

The main purpose of this study is to investigate the self-efficacy levels of pre-service science teachers who participated in a workshop with physical laboratory implementations supported by digital simulations and determine their views on digital simulations.

### Participants

This study was carried out with 16 university students studying in the science education department of a public university in the spring term. All pre-service teachers voluntarily participated in this research. The average age of the participants was determined to be 19.12 years, with range between the ages of 18 and 20.

**Table 1 Demographics of participants**

Gender	n
Female	10
Male	6
Total	16

### Data Collection Tools

This study includes quantitative and qualitative data. The Science Learning Self-Efficacy (SLSE) scale which was developed by Lin and Tsai (2013) and was adapted into Turkish and for physics lesson by Alpaslan and Işık (2016) was used to collect quantitative data. Alpaslan and Işık

(2016) stated that the scale, with 5-point Likert type and 5 factors in 27 items, was valid and reliable as a result of their scale adaptation study which they conducted with 193 participants. The factors of the scale were called conceptual understanding (CU), higher-order cognitive skills (HCS), practical work (PW), everyday application (EA), and science communication (SC).

In this study, a structured interview form (Table 2) was also used as a data collection tool. The structured interview process is defined as asking the same questions to participants with the same statements and in the same order (Corbetta, 2003). Three questions which comprised the interview form in the study were asked to all participants respectively.

**Table 2 Interview guide**

Phase	Directions	Time
Beginning	Clarifying the aim of the interview	5-6 min.
	Informing about confidentiality of the study	
	Asking permission for recording	
Questions	1. What do you think about whether the digital simulations you experienced with Crocodile Physics are integrated into educational environments?	20-25 min.
	2. What do you think about the effects of digital simulations you experienced with Crocodile Physics on educational environments?	
	3. Can you compare free-hand experimenting and experimenting with Crocodile Physics, please?	

### Data Collection Process

The data collection process was carried out within the scope of the workshop which continued for 6 weeks in 2-hour sessions per week. In this process, a digital simulation program called Crocodile Physics, which was developed by Crocodile Company, was used. Crocodile Physics was updated and transferred to Yenka, which is a new software platform ([www.yenka.com](http://www.yenka.com)).

Crocodile Physics is a computer program which is used to design virtual experiments. One of the reasons for choosing this program in this study is that it offers easy use. Indeed, Le Thang (2014) stated that users can easily use virtual laboratory equipment with symbols and looks similar to their appearance in a real laboratory through Crocodile Physics and similar programs. Crocodile Physics provides both symbols and real appearance of laboratory equipment to its users.

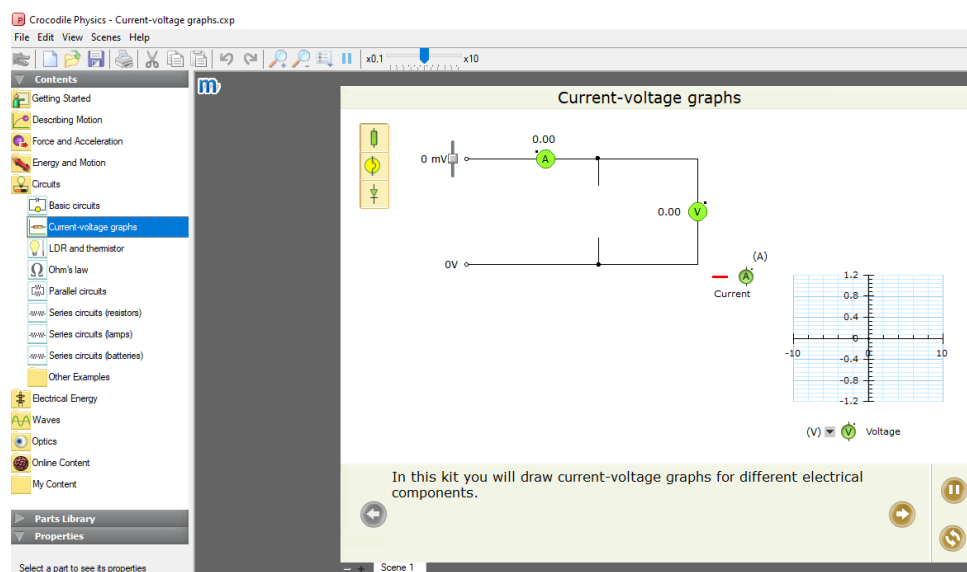

**Figure 1. Screenshot from Crocodile Physics**

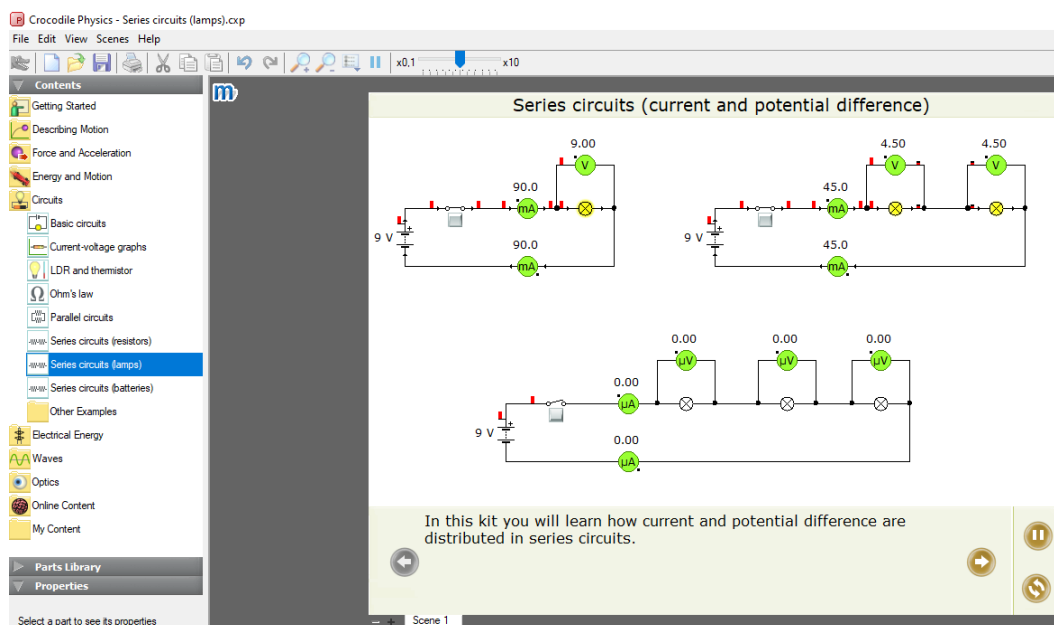

**Figure 2. Screenshot from Crocodile Physics**

At the beginning of the workshop, participants were informed about the process. Then the Crocodile Physics program and its tabs are introduced. Throughout the process, the experiments regarding the topics that are presented in Table 3 were followed, respectively. Worksheets that included various information about the experiment were presented at the beginning of each session to participants. Subheadings in the worksheets were as follows: (1) name of experiment, (2) purpose of experiment, (3) equipment, (4) procedure for experiment, (5) data, and (6) results of experiment.

**Table 3 Workshop content**

Week	Subject
1	Pre-test implementation Explanation about the content of the workshop Introduction to Crocodile Physics
2	Circuit components and basic circuits
3	Ohm's Law
4	Series Circuits
5	Parallel Circuits
6	General review Post-test implementation

The participants performed experiments with Crocodile Physics in accordance with the instructions in the worksheets. During this process, they recorded their experimental data in the data section of the worksheets. Then, they generated the experimental results section with calculations and the results they obtained with the data. Examples of digital simulations which were designed with Crocodile Physics by pre-service science teachers are presented as follows:

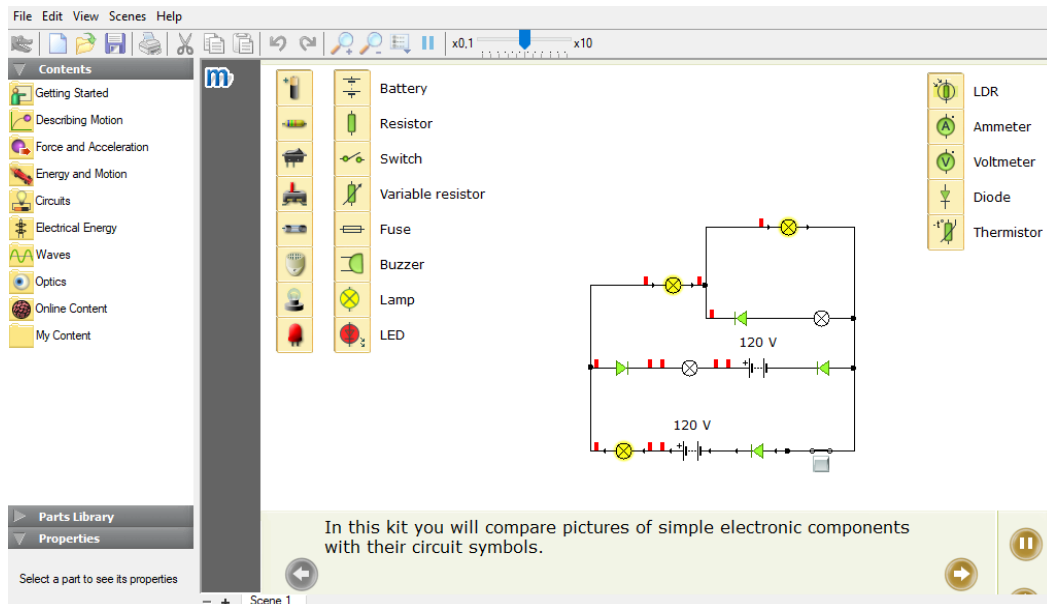

Figure 3. Screenshot from Crocodile Physics

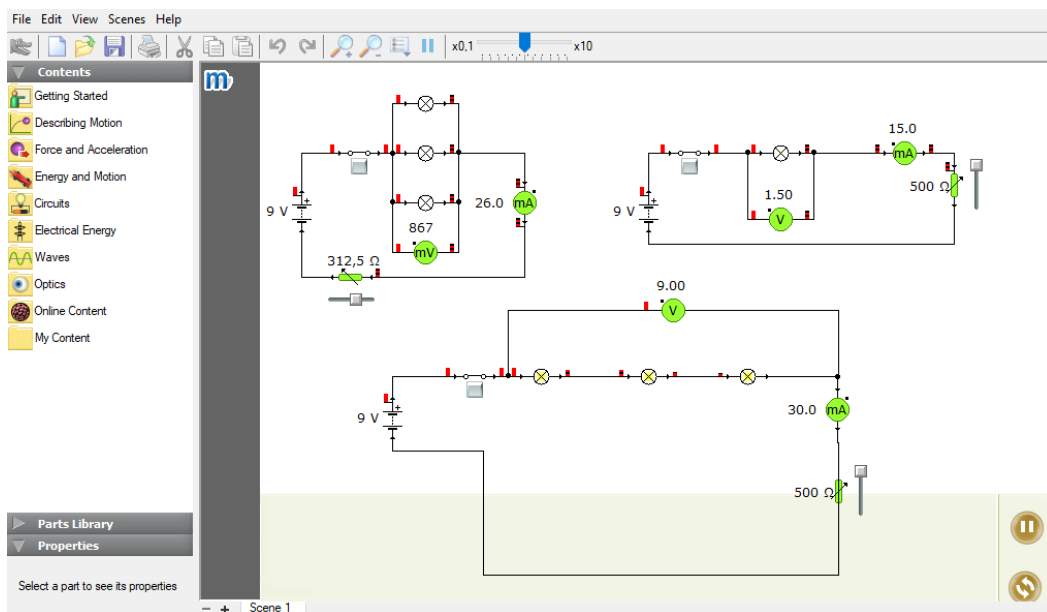

Figure 4. Screenshot from Crocodile Physics

### Data Analysis

This study consists of quantitative and qualitative data. Quantitative data in the research was analyzed with SPSS package software. At this point, normal distribution was firstly examined. Since the sample size is less than 50, the Shapiro-Wilk test was used to examine whether the pre-test and post-test averages show normal distribution. It was determined that the data set did not display normal distribution. For this reason, the relationship between the pre-test and post-test averages was analyzed with the Mann-Whitney U test.

In the analysis process for qualitative data, the constant comparative method was used. This analysis method begins with open coding (Boeije, 2002; Mills et al., 2006; Strauss, 1987) by comparing the data with other data throughout the coding analysis (Fram, 2013). Open coding is an interpretation process based on the analytical disjunction of the data obtained. In this coding process, events, actions or interactions are compared with others in accordance with their similarities or

differences. At this point, the compared events, actions or interactions are labeled. Thus, events, actions or interactions which are conceptually similar are grouped together to generate categories and subcategories (Corbin & Strauss, 1990). After this phase, the axial coding process was started (Boeije, 2002). Axial coding is the process of evaluating the relationships between categories, their features and dimensions (Corbin & Strauss, 2008). In order to protect the privacy of the participants, each interview record was coded as PST1, ..., PST16. Interview transcriptions were made with these codes and they were also used for examples of participant responses.

## FINDINGS

In the data analysis process, firstly normal distribution of the quantitative data set was examined. At this stage, since the number of participants is less than 50, the Shapiro-Wilk test (Büyüköztürk, 2012) was used. As a result of the analysis, it was concluded that the data set didn't show normal distribution ( $p < .05$ ) (Büyüköztürk, 2012). Therefore, the analysis procedure for the data was continued with the Mann-Whitney U test, which is one of the non-parametric hypothesis tests. The analysis results obtained are presented in Table 4.

**Table 4 Analysis results of pre-test and post-test scores**

	<b>n</b>	<b>Mean Rank</b>	<b>Sum of Ranks</b>	<b>U</b>	<b>p</b>
Pre-test	16	12.06	193.00	57.00	.007*
Post-test	16	20.94	335.00		

\* $p < .05$

According to analysis results from the Mann-Whitney U test, there was a significant difference between self-efficacy levels of pre-service teachers at the beginning of the process and their self-efficacy levels at the end of the workshop ( $U = 57.00$ ,  $p < .05$ ). Considering the mean rank, the post-test average is higher than pre-test average. This finding shows that the workshop process supported by digital simulations is effective in increasing the self-efficacy levels of the participants.

After this stage, differences for each scale factor were examined one by one. The results of the analysis for factors termed conceptual understanding (CU), higher-order cognitive skills (HCS), practical work (PW), everyday application (EA), and science communication (SC) are presented in Table 5.

**Table 5 Analysis results of pre-test and post-test scores for factors**

	<b>n</b>	<b>Mean Rank</b>	<b>Sum of Ranks</b>	<b>U</b>	<b>p</b>
Pre-test of CU	16	12.56	201.00	65.00	.016*
Post-test of CU	16	20.44	327.00		
Pre-test of HCS	16	13.78	220.50	84.50	.095
Post-test of HCS	16	19.22	307.50		
Pre-test of PW	16	12.53	200.50	64.50	.015*
Post-test of PW	16	20.47	327.50		
Pre-test of EA	16	12.13	194.00	58.00	.007*
Post-test of EA	16	20.88	334.00		
Pre-test of SC	16	13.75	220.00	84.00	.087
Post-test of SC	16	19.25	308.00		

\* $p < .05$

When Table 5 is investigated, post-test mean ranks of factors termed HCS and SC are higher than mean ranks for the pre-test. However, these differences are not statistically significant ( $p > .05$ ). In addition to this, post-test mean ranks for CU, PW and EA are higher than their pre-test mean ranks with a statistically significant difference. In light of these findings, the 6-week workshop had a positive effect on developing CU, PW and EA, but the workshop was not effective for the other two factors (HCS and SC).



Findings related to the interview questions used in obtaining qualitative data are presented in the following section.

Question 1: What do you think about whether the digital simulations you experienced with Crocodile Physics are integrated into educational environments?

Most of the pre-service teachers ( $n = 15$ ) who participated in this study reported positive views regarding the use of digital simulations in educational environments. However, PST16 stated that computer programs such as Crocodile Physics should only be used for enhancement purposes, not on teaching course subject matter or laboratory practices. Some participants who expressed positive opinions about supporting educational processes with digital simulations explained their thoughts in accordance with various conditions. For example, most of the participants expressed their views that digital simulations alone should not be used in classroom environments and underlined that laboratory activities should be carried out both with digital simulation programs and free-hand experiments. In addition, some participants ( $n = 2$ ) stated that these programs should be used when needed, not always. Examples of participant responses are presented as follows:

PST3: "I enjoyed the Crocodile Physics program. Thanks to the experiments carried out with this program, the course subject was reinforced. I think the subject matter became more understandable. I think this program and the like should be used in courses such as physics and chemistry..."

PST7: "When a course is supported with visuals, the course becomes more permanent in the student's mind. Theoretical knowledge is forgotten after a certain time, as it is very memorized. For this reason, I think programs like Crocodile Physics should be used in science courses."

PST8: "In my opinion, it is not enough to perform experiments only manually or only with a program in laboratory activities. So I think they should always be used together. I mean we should always do an experiment with both our hands and computer programs. After my experience in this lesson, I think it is better for us to use both together."

PST10: "Crocodile Physics is a very good program. But this situation doesn't mean that we always use the program. Of course, programs make the courses more understandable and fun. However, manual experiments and virtual experiments will not be the same. So just using one of them would be against logic. The computer programs should be used on a needs basis. Such programs are useful if they are used when there is a need..."

When participant responses for this question are examined, it was noteworthy that in an educational process carried out with digital simulations and free-hand experiments, the opinions regarding the priority order of these activities were expressed. At this point, 9 participants evaluated working with digital simulations first and then performing free-hand experiments as more useful. Four participants, on the other hand, stated that an opposite method of implementation would be more effective. Examples of participant responses for these views are presented below:

PST1: "It is more efficient to conduct the laboratory course with the program. It is more efficient for us to do the experiment manually first and then apply it with the program."

PST14: "Laboratory experiments should be shown first with the program. After working with the program, we must establish our own setup using our laboratory materials and make our experience. In this way it will be more beneficial to us."

PST15: "It would be more useful if we use the program before the experiments. We will make fewer errors in experiments and set up the assemblies more easily..."

Question 2: What do you think about the effects of digital simulations you experienced with Crocodile Physics on educational environments?

While participants were answering this question, they especially focused on the effects of digital simulations on two processes of experiment and course. In this context, the answers given to this question are classified under two categories termed as “effect on experiments” and “effect on course”. While there are five codes under the category of effect on experiment, the effect on course category consists of six codes. Through axial coding, the relationship between these two categories and the codes which they contain was examined and "learning process" category was obtained with this combination. These categories and codes are presented in the following table.

**Table 6 Participant opinions about digital simulations used in learning processes**

Category	Code	n
Effect on Experiment	Learning installation of circuits easily	12
	Compensation for damaged/missing laboratory equipment	11
	Investigating experimental data in detail	9
	Decreasing experimental errors	9
	More trial-and-error opportunities	8
	Saving time	3
Effect on Course	Efficient	13
	Increasing clarity	12
	Learning with fun	10
	Learning by discovery	8
	Permanent learning	7
	Enhancement of subject matter	4

While the majority of the participants (n = 13) expressed their opinions about the use of digital simulations in learning processes, they stated that the Crocodile Physics program is easy to use. When the participant responses about the effects of digital simulations on experimental design were examined, pre-service teachers (n = 12) determined that they learned to install electrical circuits more easily through digital simulations. However, another highlighted point (n = 11) is that digital simulations are ways to compensate for missing or damaged equipment in the laboratory. In addition, the opinions that different experimental data can be easily examined with digital simulations and that the error margins of the experiments can be reduced with reliable measurement results were emphasized by 9 participants. Also, 8 participants reported that the trial-and-error method can be used quickly with digital simulations and this situation makes it easier to achieve the right results or compare data. Three participants also identified that this process, which speeds up the examination of the experimental data, will save time. The category called effect on the course which includes participant responses about the impacts of digital simulations on laboratory courses focuses on the advantages of a course where simulations are integrated. At this point, Table 2 shows that the most emphasized participant response (n = 13) is efficient lessons. Similarly, participants (n = 12) underlined that a clearer presentation of the subject matter was provided through digital simulations. It was stated that these computer programs provide learning by having fun (n = 10) and discovery (n = 8). Some participants (n = 7) explained the effect of digital simulations on learning with permanent learning. In addition, 4 participants reported that simulations played an important role in reinforcing the subject matter of the course. Examples of participant responses for these opinions are presented as follows:

PST1: “... We investigated the values of the experiment with the program in the most efficient way ... I understand the physics laboratory course with the program. I do the experiments by trial and error. In short, I think the course became more efficient with this program.”

PST2: "I think Crocodile Physics is good. Thanks to the program, I learned to install the circuits more easily. Actually, I wasn't a person who was able to install circuits, but thanks to the program, I learned to install circuits more quickly."

PST5: "This program should definitely be used by students for physics experiments. Because there may be problems with the equipment which we use in our experiments and therefore there may be errors in the data of the experiments we measure. There are no errors in our experiment data with this program. So, our margin of error falls. The program can be learned easily, although it may seem a little complicated and time consuming."

PST6: "... Experimental equipment can sometimes be damaged in the physics laboratory. Sometimes the materials are missing. Therefore, we have problems doing the experiments. The best advantage of this program is that it eliminates such problems."

PST9: "First of all, I want to state that I have not done any experiments about physics subject matter until my graduate education. I also do not see myself as successful in physics course... But in this course Crocodile Physics was a very good program for me. I believe that these things are always more beneficial to us students. I believed in the accuracy of this a little more with this application..."

PST11: "Crocodile Physics is visually very productive. For this reason, after installing the circuit with this program, while installing the circuit manually with the experimental equipment, the visual in my head comes to life and the circuit installation becomes easier and more practical. Thanks to this program, we get more understandable experiment results. However, it is fun to use the program."

PST12: "This program which we used has benefited me a lot in the physics course. Seeing the experiments in the program before doing them is very useful when we started to do the experiment ourselves. Since we see the experiment in the program, we can install circuits much easier and faster. We also save time with this program while making new operations by increasing or decreasing the values. Parallel and serial circuits can be installed more clearly, and the circuits are more memorable. I am a person who gets bored in class in general, I am not bored in this course due to this program."

PST13: "I like Crocodile Physics. The use of the program with laboratory activities was very effective. Both the experiment which we worked on the computer and the experiment which we did with our equipment helped me to interpret the subject matter better."

PST14: "... Crocodile Physics contributed a lot to me. It simplified the lesson. I was having trouble installing serial and parallel circuits before. I did not know what and where to connect when I installed the circuit. I learned circuit elements with the program."

Question 3: Can you compare free-hand experimenting and experimenting with Crocodile Physics, please?

When the responses of the participants related to this question were investigated, pre-service teachers maintained their positive tendencies regarding digital simulations. However, they stated that free-hand experiments should be carried out together with computer programs. In this context, they especially determined that free-hand experiments are important in recognizing laboratory equipment and learning the use of this equipment ( $n = 12$ ). In addition, they stated that individuals who learned to establish real mechanisms by identifying laboratory equipment can be successful in solving the related problems which they encounter in their daily life ( $n = 5$ ). Examples of opinions expressed, apart from these opinions, are presented below:

PST1: "By doing the experiment with our own hands, we learn how the circuits in the experiment will be installed. And then, we observe the data clearly with the program."

PST4: “I think it would be better to use both laboratory materials and computer programs in physics courses while doing experiments. While doing experiments manually, the equipment can be broken, or the bulb can explode. We can overcome these deficiencies with the computer. While doing manual experiments, we can find out what each equipment does and how they work by touching the equipment as if we were playing with them which we did not see in our previous science courses.

## DISCUSSION AND CONCLUSION

The aim of this study is to investigate the self-efficacy levels of pre-service science teachers who participated in a workshop with physical laboratory implementations supported by digital simulations and determine their opinions about digital simulations. In accordance with this purpose, a 6-week workshop based on digital simulations was designed. In this process, Crocodile Physics was used to design digital simulations for circuits.

This study consists of quantitative and qualitative data. The Science Learning Self-Efficacy (SLSE) scale was used to collect quantitative data. According to analysis results for SLSE, self-efficacy levels towards physics of pre-service science teachers were significantly developed. Considering that self-efficacy beliefs are most affected by mastery experiences (Bandura, 1994), the workshop supported by digital simulations, which provided pre-service teachers with the opportunity to experience experiments first-hand, may be the source of this increase in self-efficacy levels.

When the difference between each scale factor is analyzed in itself, it is concluded that the change in the factors named CU, PW and EA was statistically significant. In this context, it may be determined that digital simulations support conceptual understanding, practical work and everyday application. Conceptual understanding represents individual confidence in understanding physics laws, theories and concepts. Practical work, on the other hand, is explained as the confidence to perform physics laboratory activities at the cognitive and psychomotor level. However, everyday application refers to the understanding of physics and for integrating skills into daily life (Alpaslan & Işık, 2016; Lin & Tsai, 2013). The significant increases in the self-efficacy levels of pre-service teachers related to these three factors are attributed to the process they actively carried out in the laboratory.

According to analysis results for HCS and SC, there was no statistically significant difference. Based on these findings, the workshop supported by digital simulations was not effective for supporting higher-order cognitive skills and science communication. Higher-order thinking skills consist of more complex subjects and these subjects require higher-order thinking skills such as critical thinking and scientific inquiry (Alpaslan & Işık, 2016; Lin & Tsai, 2013). There is no activity related to the development of higher-order thinking skills within the scope of the workshop organized in this study. Therefore, it is thought that the participants could not improve the HCS factor. In addition, there was no development regarding the SC factor, which represents the ability of the individual to talk and discuss physics-related issues with others. It is believed that the short duration of the workshop and the process not being supported by discussion and communication-based activities, such as arguments, is effective on obtaining this result.

According to the analysis results obtained from qualitative data, pre-service science teachers mostly have a positive tendency to integrate digital simulations into educational environments. The participants' responses to the effects of digital simulations on educational environments were shaped within the framework of categories called effect on experiment and effect on course. The participants mostly focused on the features of digital simulations that provide savings in terms of time and trial attempts, and ease of learning the process of installing circuits and conducting experiments. In the category of effect on course, pre-service teachers highlighted the efficiency of the lesson process and underlined advantages such as learning by discovery and permanent learning. Additionally, creating a fun learning environment through digital simulations was emphasized. In light of these findings, it can be stated that the participants are disposed to support the activities of the physics lab with digital simulations. It is thought that the possibilities offered by digital simulations designed with Crocodile

Physics in terms of both visual aspects and ease of use may be effective on this situation. Indeed, Le Thang (2014) explained that the course process will be much more vivid with Crocodile Physics, and thus high efficiency will be achieved.

Participants also stated that it would be beneficial to perform digital simulation implementations and free-hand experiments sequentially in laboratory processes by comparing free-hand experiments and experiments designed with digital simulations. At this point, they determined that they want to have the opportunity to identify the laboratory materials by touching and experiencing them firsthand.

In the findings obtained from qualitative data, codes termed “more trial-and-error opportunities” and “compensation for damaged/missing laboratory equipment” were formed. According to these findings, pre-service teachers thought that the implementation process, which allows the participants to practice more, contributes to their own development. In this context, the significant increase in the PW factor is due to the positive perspectives of the participants towards the practices they experienced in this process. As a matter of fact, Espinosa, Miller, Araujo and Mazur (2019) reported that active teaching strategies can be effective on self-efficacy development. From this point of view, it can be concluded that this process, which participants actively experience, is reflected in the PW factor.

The codes termed “learning installation of circuits easily”, “efficient”, “learning with fun”, “learning by discovery”, “increasing clarity”, “permanent learning”, and “enhancement of subject matter” were also derived from analysis of qualitative data. At this point, pre-service teachers thought that the practices in the research process they participated in had a positive effect on their conceptual understanding. Indeed, when the related literature is investigated, there are studies which underline contributions of simulations to learning. For example, Squire, Barnett, Grant and Higginbotham (2004) conducted an experimental study which focused on teaching of electromagnetism. The researchers reported that simulations have a positive effect on student understanding. Similarly, as an example from this study, pre-service teachers indicated that they could learn the subject matter of circuits easily with digital simulations. In this context, these perceptions of participants cause development of the CU factor. Indeed, learners can develop positive efficacy beliefs with a simulation-based educational environment towards learning (Gegenfurtner, Quesada-Pallarès & Knogler, 2014).

The significant increase in the EA factor can be evaluated as enabling pre-service teachers to conduct more detailed data research during the implementation process. Limitations caused by situations such as material or time constraints may be encountered in the laboratory are irrelevant in the digital simulation environment. In this way, the participants have the chance to try their own designs. In fact, in this study, the code termed “investigating experimental data in detail” was created with qualitative analysis. According to the results of the study, it is suggested that digital simulations that enable active learning (Miller, 1984; Woodward, Carnine & Gersten, 1988) can be used to develop self-efficacy levels of learners.

## REFERENCES

- Alpaslan, M. M. & Işık, H. (2016). Fizik öz-yeterlilik ölçeği'nin geçerliliği ve güvenilirliği/Examination of the validity and the reliability of physics self-efficacy scale. *Mustafa Kemal Üniversitesi Sosyal Bilimler Enstitüsü Dergisi*, 13(33).
- Bandura, A. (1982). *Self-efficacy mechanism in human agency*. *American Psychologist*, 37(2), 122-147.
- Bandura, A. (1994). Self-efficacy. In V. S. Ramachaudran (Ed.), *Encyclopedia of human behavior* (Vol. 4, pp. 71-81). New York: Academic Press. (Reprinted in H. Friedman [Ed.], *Encyclopedia of mental health*.) San Diego: Academic Press.

- Bandura, A. (1995). Exercise of personal and collective efficacy in changing societies. In A. Bandura (Ed.), *Self-efficacy in changing societies* (pp. 1-45). Cambridge: Cambridge University Press.
- Bandura, A. (1997). *Self-efficacy: The exercise of control*. New York: Freeman.
- Bautista, N. U., & Boone, W. J. (2015). Exploring the impact of TeachME™ lab virtual classroom teaching simulation on early childhood education majors' self-efficacy beliefs. *Journal of Science Teacher Education*, 26(3), 237-262.
- Bingimlas, K. A. (2009). Barriers to the successful integration of ICT in teaching and learning environments: A review of the literature. *Eurasia Journal of Mathematics, Science & Technology Education*, 5(3), 235-245.
- Boeije, H. (2002). A purposeful approach to the constant comparative method in the analysis of qualitative interviews. *Quality and Quantity*, 36(4), 391-409.
- Brun, M. & Hinostroza, J. E. (2014). Learning to become a teacher in the 21st century: ICT integration in initial teacher education in Chile. *Educational Technology & Society*, 17, 222-238.
- Büyüköztürk, Ş. (2012). *Sosyal bilimler için veri analizi el kitabı: İstatistik, araştırma deseni, SPSS uygulamaları ve yorum*. Ankara: Pegem Akademi.
- Clark, D., Nelson, B., Sengupta, P. & D'Angelo, C. (2009, October). Rethinking science learning through digital games and simulations: Genres, examples, and evidence. In Learning science: Computer games, simulations, and education workshop sponsored by the National Academy of Sciences, Washington, DC.
- Collins, A. (1990). The role of computer technology in restructuring schools. *Restructuring for Learning with Technology*, December 1990, 31-46.
- Corbetta, P. (2003). *Social research: Theory, methods and techniques*. Sage.
- Corbin, J. M. & Strauss, A. (1990). Grounded theory research: Procedures, canons, and evaluative criteria. *Qualitative Sociology*, 13(1), 3-21.
- Corbin, J. & Strauss, A. (2008). *Basics of qualitative research (3rd ed.): Techniques and procedures for developing grounded theory*. Thousand Oaks, CA: SAGE Publications.
- Creswell, J. W. (2012). *Educational research: Planning, conducting, and evaluating quantitative and qualitative research*. Boston, MA: Pearson Education.
- Creswell, J. W. & Plano Clark, V. L. (2011). *Designing and conducting mixed methods research*. Thousand Oaks, CA: Sage.
- De Jong, T. (1991). Learning and instruction with computer simulations. *Education and Computing*, 6(3-4), 217-229.
- Dekkers, J. & Donatti, S. (1981). The integration of research studies on the use of simulation as an instructional strategy. *The Journal of Educational Research*, 74(6), 424-432.
- Dou, R., Brewster, E., Zwolak, J. P., Potvin, G., Williams, E. A., & Kramer, L. H. (2016). Beyond performance metrics: Examining a decrease in students' physics self-efficacy through a social networks lens. *Physical Review Physics Education Research*, 12(2), 020124.

- Ertmer, P. A. & Ottenbreit-Leftwich, A. T. (2010). Teacher technology change: How knowledge, confidence, beliefs, and culture intersect. *Journal of Research on Technology in Education*, 42(3), 255-284.
- Espinosa, T., Miller, K., Araujo, I., & Mazur, E. (2019). Reducing the gender gap in students' physics self-efficacy in a team-and project-based introductory physics class. *Physical Review Physics Education Research*, 15(1), 010132.
- Fencl, H. S. & Scheel, K. R. (2004, September). Pedagogical approaches, contextual variables, and the development of student self-efficacy in undergraduate physics courses. In *AIP Conference Proceedings* (Vol. 720, No. 1, pp. 173-176). American Institute of Physics.
- Fram, S. M. (2013). The constant comparative analysis method outside of grounded theory. *Qualitative Report*, 18, 1.
- Fullan, M. & Stiegelbauer, S. (1991). *The new meaning of educational change*. New York: Teachers College Press.
- Gegenfurtner, A., Quesada-Pallarès, C. & Knogler, M. (2014). Digital simulation-based training: A meta-analysis. *British Journal of Educational Technology*, 45(6), 1097-1114.
- Gundel, E., Piro, J. S., Straub, C., & Smith, K. (2019). Self-efficacy in mixed reality simulations: Implications for preservice teacher education. *The Teacher Educator*, 54(3), 244-269.
- Hazari, Z., Sonnert, G., Sadler, P. M., & Shanahan, M. C. (2010). Connecting high school physics experiences, outcome expectations, physics identity, and physics career choice: A gender study. *Journal of Research in Science Teaching*, 47(8), 978-1003.
- Jonassen, D.H. (1992). This is a chapter. In E. Scanlon & T. O'Shea (Ed.). *New directions in educational technology* (pp. 123-131). New York: Springer-Verlag.
- Kinzie, M. B., Delcourt, M. A. & Powers, S. M. (1994). Computer technologies: Attitudes and self-efficacy across undergraduate disciplines. *Research in Higher Education*, 35(6), 745-768.
- Kozlowski, S. W., Gully, S. M., Brown, K. G., Salas, E., Smith, E. M., & Nason, E. R. (2001). Effects of training goals and goal orientation traits on multidimensional training outcomes and performance adaptability. *Organizational Behavior and Human Decision Processes*, 85(1), 1-31.
- Le Thang, N. (2014). Using crocodile physics software to design virtual experiments in physics teaching at schools (Vietnam). *Научно-методический и теоретический журнал*, (1), 229.
- Li, Y., Wang, K., Xiao, Y., & Froyd, J. E. (2020). Research and trends in STEM education: a systematic review of journal publications. *International Journal of STEM Education*, 7(1), 1-16.
- Lin, T. J. & Tsai, C. C. (2013). A Multi-Dimensional Instrument for Evaluating Taiwanese High School Students' Science Learning Self-Efficacy in Relation to Their Approaches to Learning Science. *International Journal of Science and Mathematics Education*, 11(6), 1275-1301.
- Lindgren, R. & Schwartz, D. L. (2009). Spatial learning and computer simulations in science. *International Journal of Science Education*, 31(3), 419-438.

- Lindström, C. & Sharma, M. D. (2011). Self-efficacy of first year university physics students: Do gender and prior formal instruction in physics matter?. *International Journal of Innovation in Science and Mathematics Education* (formerly CAL-laborate International), 19(2).
- Marshman, E. M., Kalender, Z. Y., Nokes-Malach, T., Schunn, C., & Singh, C. (2018). Female students with A's have similar physics self-efficacy as male students with C's in introductory courses: A cause for alarm?. *Physical Review Physics Education Research*, 14(2), 020123.
- Matzen, N. J. & Edmunds, J. A. (2007). Technology as a catalyst for change: The role of professional development. *Journal of Research on Technology in Education*, 39(4), 417-430.
- Miller, M. D. (1984). The use of simulations in training programs: A review. *Educational Technology*, 24(11), 39-42.
- Mills, J., Bonner, A. & Francis, K. (2006). The development of constructivist grounded theory. *International Journal of Qualitative Methods*, 5(1), 25-35.
- Nissen, J. M., & Shemwell, J. T. (2016). Gender, experience, and self-efficacy in introductory physics. *Physical Review Physics Education Research*, 12(2), 020105.
- Roschelle, J., Abrahamson, L. A. & Penuel, W. R. (2004, April). Integrating classroom network technology and learning theory to improve classroom science learning: A literature synthesis. Paper presented at the meeting of the American Educational Research Association. San Diego, CA.
- Sawtelle, V., Brewe, E. & Kramer, L. H. (2010, October). Positive impacts of modeling instruction on self-efficacy. In AIP Conference Proceedings (Vol. 1289, No. 1, pp. 289-292). American Institute of Physics.
- Sawtelle, V., Brewe, E., & Kramer, L. H. (2012). Exploring the relationship between self-efficacy and retention in introductory physics. *Journal of Research in Science Teaching*, 49(9), 1096-1121.
- Squire, K., Barnett, M., Grant, J. M., & Higginbotham, T. (2004). Electromagnetism supercharged! Learning physics with digital simulation games. In Kafai, Y. B., Sandoval, W. A., Enyedy, N., Nixon, A. S., & Herrera, F. (Eds.), *International Conference of the Learning Sciences 2004: Embracing Diversity in the Learning Sciences* (pp. 513-520). Santa Monica, CA: Lawrence Erlbaum Associates.
- Strauss, A. L. (1987). *Qualitative analysis for social scientists*. New York, NY: Cambridge University Press.
- Takeuchi, M. A., Sengupta, P., Shanahan, M. C., Adams, J. D., & Hachem, M. (2020). Transdisciplinarity in STEM education: A critical review. *Studies in Science Education*, 56(2), 213-253.
- Tondeur, J., van Braak, J., Sang, G., Voogt J., Fisser, P. & Ottenbreit-Leftwich, A. (2012). Preparing pre-service teachers to integrate technology in education: A synthesis of qualitative evidence. *Computers & Education*, 59(1), 134-144.
- Wang, L., Ertmer, P. A. & Newby, T. J. (2004). Increasing preservice teachers' self-efficacy beliefs for technology integration. *Journal of Research on Technology in Education*, 36(3), 231-250.



- Wilson, J. I. (2002). A visit to the Springdale school system in 2012. *Visions 2020: Transforming education and training through advanced technologies.*
- Woodward, J., Carnine, D. & Gersten, R. (1988). Teaching problem solving through computer simulations. *American Educational Research Journal, 25*(1), 72-86.
- Yerdelen-Damar, S., & Peşman, H. (2013). Relations of gender and socioeconomic status to physics through metacognition and self-efficacy. *The Journal of Educational Research, 106*(4), 280-289.
- Yoder, S. (1994). Math, microworlds, and hypermedia. *The Computing Teacher, 21*(8), 18-20.